

DURABLE. RELIABLE. DEPENDABLE.



**HEAVY-DUTY BASE
MOUNTED C-FACE EVEN
WEAR EXTENDED SHAFT
SLURRY PUMP**

**BCEW
SERIES**

SPECIFICATIONS

FEATURES

- Heavy duty closed impeller for pumping abrasive solids.
- 28% High Chrome 650+ Brinell hardness assures long life of impeller, wear plate and casing.
- Double mechanical seal with Silicon Carbide vs. Silicon Carbide seal faces running in a barrier fluid for lubrication and cooling.
- C-Face inverter-duty TEFC, severe service, low voltage motor minimizes the cost of operation.
- Thrust bearing support is in close proximity to impeller to minimize shaft deflection.

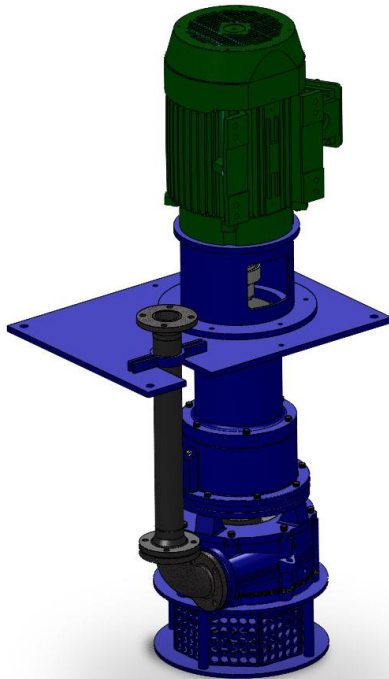

SPECIFICATIONS

Horsepower
Discharge Size
Performance Range
Capacity
Head
Max Particle Size
Motor Nomenclature
Type / Speed / HZ

Voltage / Phase
Service Factor
Insulation
Maximum Water Temperature
Operation Mode
Materials of Construction
Casing

Impeller

Wear Plate

Shaft
Bearing Housing
Fasteners
Impeller Type
Mechanical Seal
Seal Faces
Elastomers
Labyrinth Seal
Lubrication
Bearings
Thrust
Radial
Lubrication

Accessories

STANDARD

15 - 800 HP
3" – 8"

250 - 6000 US GPM
50' – 350' TH
3-1/4"

C-Face TEFC / 900 to 1800 RPM / 60 HZ
230, 460, 575 V / 3 Phase
1.15
Class F
200° F
Synchronous Speed or V.F.D.

28% High Chrome 650+ Brinell Hardness
28% High Chrome 650+ Brinell Hardness
28% High Chrome 650+ Brinell Hardness
416 Stainless Steel
Cast Iron
18-8 Stainless Steel
Enclosed

Silicon Carbide
Viton
Stainless Steel/Cast Steel
Mobil / Synturion 6

Double Angular Contact
Deep Groove Ball Bearing
Permanently Lubricated with Mobil SHC Polyrex 222
Agitators / Discharge Hose / Variable Speed / Urethane Coating / Elbows in Steel or High Chrome / Control Panels / Moisture and Thermal Protection / Rafts

**Pumps are available for up to 20' sumps.
No V-belts or tail pipes required.**

